



Intel® Visual Compute Accelerator VCA1283LVV

Product Specification and Hardware User's Guide

A reference document used to provide a high level overview of product features and support requirements.

Revision 1.1
November 2015

Intel® Server Boards and Systems

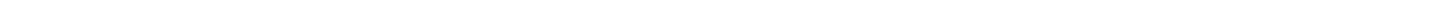

Document Revision History

Date Published	Revision	Revision Change Description
October 2015	1.0	Production - First Public Release
November 2015	1.1	Added Max TDP data to Board Feature set table in section 2.2

Disclaimer

Intel technologies' features and benefits depend on system configuration and may require enabled hardware, software or service activation. Learn more at Intel.com, or from the OEM or retailer.

You may not use or facilitate the use of this document in connection with any infringement or other legal analysis concerning Intel products described herein. You agree to grant Intel a non-exclusive, royalty-free license to any patent claim thereafter drafted which includes subject matter disclosed herein.

No license (express or implied, by estoppel or otherwise) to any intellectual property rights is granted by this document.

The products described may contain design defects or errors known as errata which may cause the product to deviate from published specifications. Current characterized errata are available on request.

Intel disclaims all express and implied warranties, including without limitation, the implied warranties of merchantability, fitness for a particular purpose, and non-infringement, as well as any warranty arising from course of performance, course of dealing, or usage in trade.

Intel, the Intel logo, and Intel Xeon, are trademarks of Intel Corporation in the U.S. and/or other countries.

*Other names and brands may be claimed as the property of others.

Copyright © 2015 Intel Corporation. All Rights Reserved.

Table of Contents

1. INTRODUCTION.....	1
1.1 DOCUMENT OUTLINE	1
1.2 OTHER REFERENCE MATERIALS.....	1
2. PRODUCT OVERVIEW	2
2.1 ORDER INFORMATION.....	2
2.2 FEATURE SET	3
2.3 SYSTEM COMPATIBILITY LIST.....	4
2.4 ARCHITECTURE BLOCK DIAGRAM	5
3. BOARD SPECIFICATIONS & SUPPORT REQUIREMENTS	6
3.1 MECHANICAL SPECIFICATION.....	6
3.2 VCA CARD ASSEMBLY	6
3.3 THERMAL AND AIR FLOW SPECIFICATION.....	7
3.4 POWER SPECIFICATION	9
3.4.1 12V AUX Power Connector Specification and Pinout	9
4. MEMORY	11
4.1 MEMORY POPULATION RULES.....	11
4.2 SUPPORTED MEMORY	11
4.3 MEMORY COMPATIBILITY LIST.....	12
5. OPERATING SYSTEM SUPPORT	13
5.1 SUPPORTED HOST OPERATING SYSTEMS	13
5.1.1 Reference boot OS on Visual Compute Accelerator	13
5.2 SUPPORTED HYPERVISOR	13
5.3 GUEST OS.....	13
6. LIGHT GUIDED DIAGNOSTICS.....	14
6.1 POWER LEDs	14
6.2 PROCESSOR CATERR LEDs	14
7. BIOS IMAGE SELECTION JUMPERS	15

List of Figures

Figure 1. Product Architectural Block Diagram.....	5
Figure 2. VCA Card Power Connectors	9
Figure 3. VCA Card DIMM Slots.....	11
Figure 4. Light Guided Diagnostics - Power State LEDs.....	14
Figure 5. Light Guided Diagnostics - Processor CATERR LEDs	14
Figure 6. VCA Card BIOS Recovery Jumpers.....	15
Figure 7. 2-Slot PCIe Riser Card.....	17
Figure 8. Auxiliary 12V Power Cable (iPC AXXGPGPUCABLE).....	17
Figure 9. Air Duct included in Intel® Accessory Kit AWT COPRODUCT	18
Figure 10. Shipping Bracket	19
Figure 11. Shipping Bracket Placement	19

1. Introduction

This document provides a high level overview of the product features, functions, and support requirements of the Intel® Visual Compute Accelerator (VCA) card.

1.1 Document Outline

This document is divided into the following chapter:

- Chapter 1 – Introduction
- Chapter 2 – Product Overview
- Chapter 3 – Board Specifications and Support Requirements
- Chapter 4 – Memory Support
- Chapter 5 – Operating System Support
- Chapter 6 – Light Guided Diagnostics
- Chapter 7 – BIOS Image Selection Jumpers
- Appendix A – Intel® Server System Support Requirements

1.2 Other Reference Materials

Intel® Visual Compute Accelerator Product Software Guide

For more information on the Intel® Visual Compute Accelerator: <http://www.intelserveredge.com/VCA>

For more information on Intel server solutions visit: <http://www.intelserveredge.com>

For product specifications visit: <http://ark.intel.com/>

To obtain technical documents, please visit: <http://www.intel.com/support/GO/visual-accelerator>



To obtain the latest download, please visit: <https://downloadcenter.intel.com/product/87380/>



2. Product Overview

The Intel® Visual Compute Accelerator card combines the Intel® Iris Pro Graphics capabilities of the Intel® Xeon® E3-1200 v4 series processor with the power of Intel® Xeon® E5-2600 v3 series processor based server systems. Designed around visual computing workloads, this PCIe add-in card can handle the highest end 4K/HEVC transcoding jobs as well as many simultaneous AVC jobs. Built for cloud service providers, Telco service providers and broadcasters who need media transcoding acceleration for the growing video market.

Outstanding Performance / Power / Price per transcode

- Real time HEVC transcode performance delivered at low cost and power

Fit within Intel® Xeon® Processor E5 Infrastructure

- Multiple 1U and 2U Server System options from several server system suppliers
- PCIe* 3.0 x16 enables fast communication between host and adapter

Flexible and Portable software architecture

- Full access to integrated CPU & GPU for best quality/performance
- Virtual network allows host and card to communicate seamlessly
- Strong ISV ecosystem for ease of solution deployment

2.1 Order Information

Intel Product Code	Order Information	Product Description	Product Type
<p>iPC – VCA1283LVV</p> 	<p>MM# – 942876 UPC – 0735858309493 EAN – 5032037081986 MOQ – 1</p>	<p>Intel® Visual Compute Accelerator Card (1) PCIe* add-in-card with 3 x Intel® Xeon® processor E3-1200 v4 series product family, 6 DIMM slots – 2 DIMMs / CPU (1) Quick Start Guide</p>	<p>PCIe* Add-in Card</p>

2.2 Feature Set

Board Feature Set

	Details
Form Factor	Full-Length, Full-Height, Double width PCIe* add-in card
CPU	3 x Intel® Xeon® E3-1200 v4 series product family, 47W TDP, 2.9GHz, 4 cores
Max TDP	235 Watts
Graphics	GT3e, Intel® Iris Pro Graphics P6300, 128MB eDRAM
PCH	1 x Intel® H87 Express Chipset per CPU
Memory	DDR3L (1.35V), ECC SODIMMs 1 slot per channel, 2 channels per CPU, Up to 32GB per CPU
PCI Express Configuration	PCIe* 3.0 x16, 4 lanes per CPU
BIOS	1 x16MB SPI Flash per CPU
Operating System Support	CentOS* 7.1, Xen or KVM support if using hypervisor

Processor Feature Set

Processor Type	Intel® Xeon® E3 1200 v4 series product family
Cache	6 MB
DMI	5 GT/s
Instruction Set	64-bit
Instruction Set Extensions	SSE4.1/4.2 AVX 2.0
# of Cores	4
# of Threads	8
Processor Base Frequency	2.9 GHz
Max Turbo Frequency	3.8 GHz
TDP	47 W
Max Memory Size (dependent on memory type)	32 GB
Max # of Memory Channels	2
Max Memory Bandwidth	29.8 GB/s
ECC Memory Supported	Yes
Processor Graphics ‡	Intel® Iris™ Pro Graphics P6300
Graphics Base Frequency	300 MHz
Graphics Max Dynamic Frequency	1.15 GHz
Graphics Video Max Memory	16 GB
Execution Units	48
Intel® Quick Sync Video	Yes

2.3 System Compatibility List

The Intel® Visual Compute Accelerator card is compatible with the following server systems. This section will be updated as additional server systems are validated by Intel or by the specified server supplier.

- **Intel**
 - Intel® Server System R2000WT Family

- **Dell***
 - Dell PowerEdge C4130

- **Supermicro***
 - Supermicro SuperServer SYS1028GQ-TR
 - Supermicro SuperServer SYS1028GQ-TRT

- **Advantech***
 - AGS-913

2.4 Architecture Block Diagram

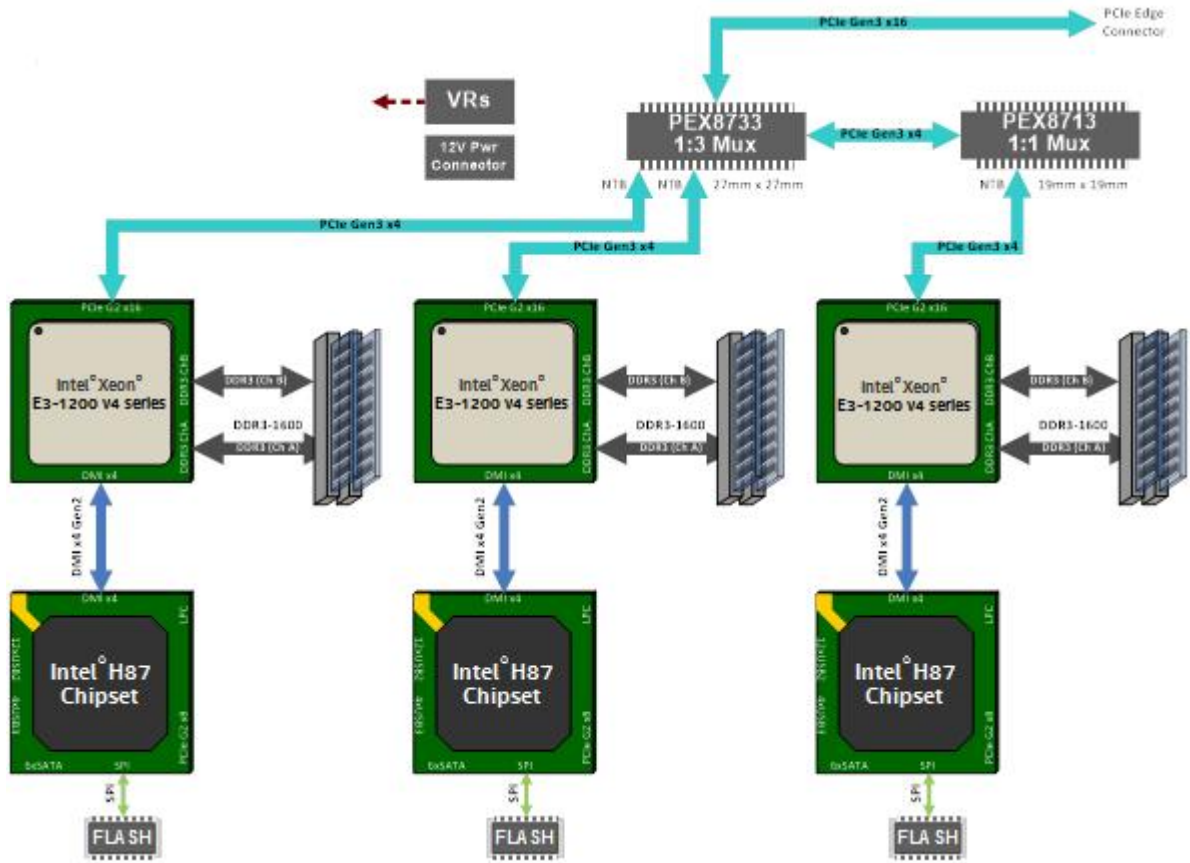
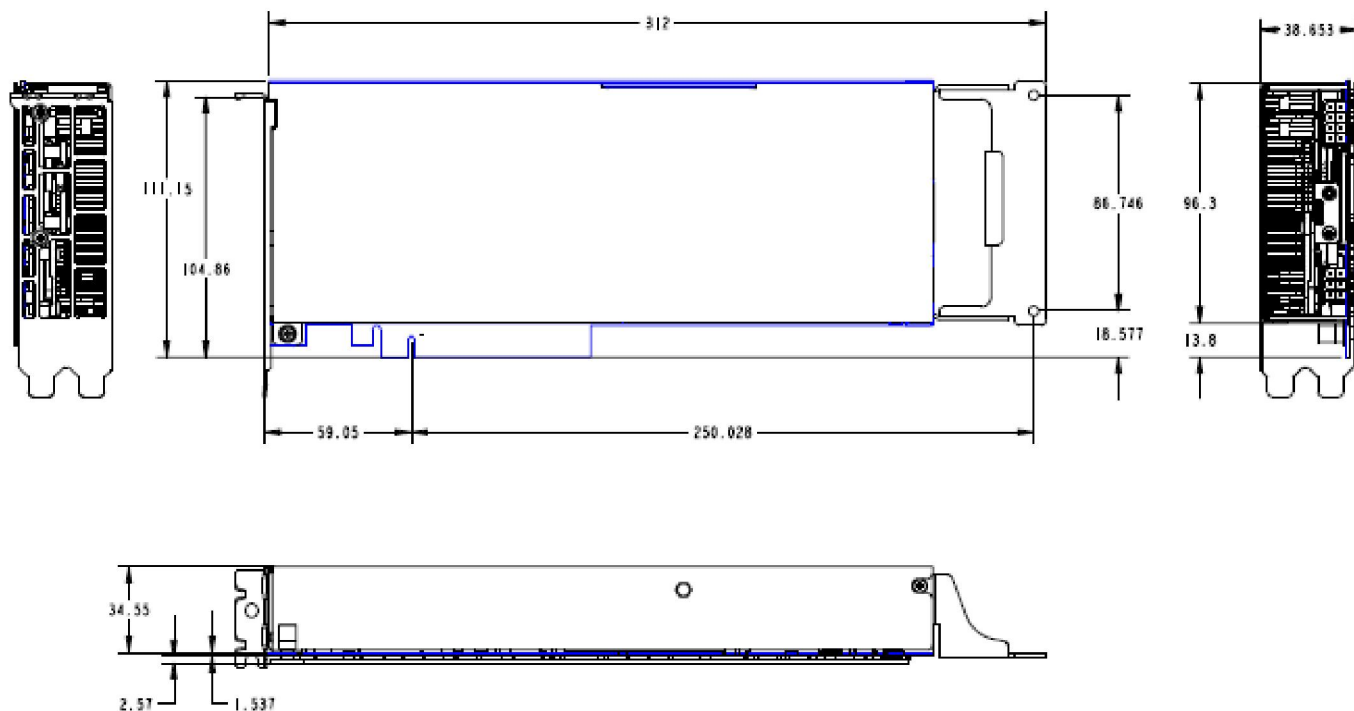

Figure 1. Product Architectural Block Diagram

3. Board Specifications & Support Requirements

3.1 Mechanical Specification

The Intel® Visual Compute Accelerator is a “near” full length, full height, double width PCIe* 3.0 x16 add-in card. It includes a bracket that extends the card to full length for systems that fully support the PCIe* specification.



3.2 VCA Card Assembly

The VCA card assembly consists of several detachable components to allow for card configuration and serviceability. The following illustration displays the full card assembly.

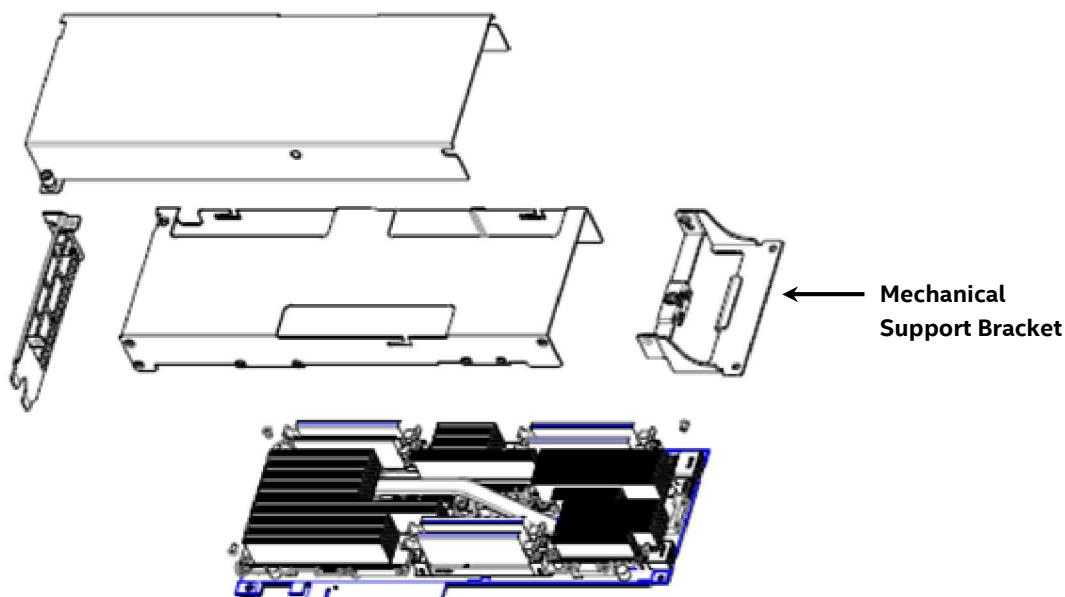

Advisory Note:

The Intel® Visual Compute Accelerator card must have the provided mechanical support bracket (or other custom support bracket) mounted to the card to ensure proper support when installed in the system. Failure to properly support the installed card may cause serious damage should the system be exposed to any level of shock or vibration or is transported to the end user location.

When in operation, the VCA card will get hot. The card covers must be in place to allow for proper air flow over and through the card assembly. Failure to have the card covers installed will result in the card overheating which may impact card performance or proper operation.

3.3 Thermal and Air Flow Specification

The following illustration and table identify the thermal, air flow, and air pressure requirements that must be met by a chassis following a common front of system to back of system air flow pattern.

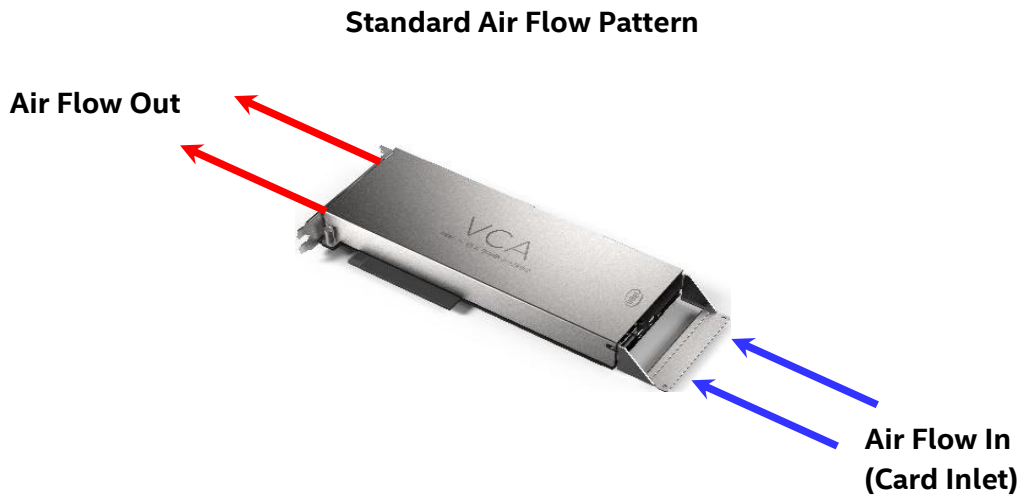

Card Inlet Temp	*Flow Rate	*Pressure Drop
45° C	25.5 CFM	0.476 "H ₂ O
35° C	18.0 CFM	0.246 "H ₂ O

*CFM=Cubic Feet per Minute

**H₂O= Inches of Water

Some custom chassis configurations may orient the card such that the air flow is reversed from the standard air flow pattern shown above. In these non-standard system configurations the thermal, air flow, and air pressure boundary conditions must meet the following requirements.

Non-Standard Air Flow Pattern



Card Inlet Temp	*Flow Rate	*Pressure Drop
35° C	24.1 CFM	0.208 "H ₂ O
25° C	19.0 CFM	0.196 "H ₂ O

*CFM=Cubic Feet per Minute

**H₂O= Inches of Water

Note: VCA card CPU core temperatures must remain at or below 96° C (204.8° F). CPU's will begin to throttle once they reach 105° C (221° F), impacting card performance. Should CPU temperatures continue to rise, the card may shut down due to a CPU Thermal Trip event. Should such events occur, system administrators must make adjustments to the system fan speed controls to ensure increased air flow to the VCA card.

System administrators can utilize the "**vcactl temp**" command of the **vcactl** utility to monitor VCA CPU core temperatures.

3.4 Power Specification

The Intel® Visual Compute Accelerator card has a max TDP of 235W. Per the PCIe* specification, the PCIe x16 connector can support up to 75W. The remaining power to the card must be supplied via the 2x3 (75W) and 2x4 (150W) 12V AUX power connectors on the card as shown in the following illustration.

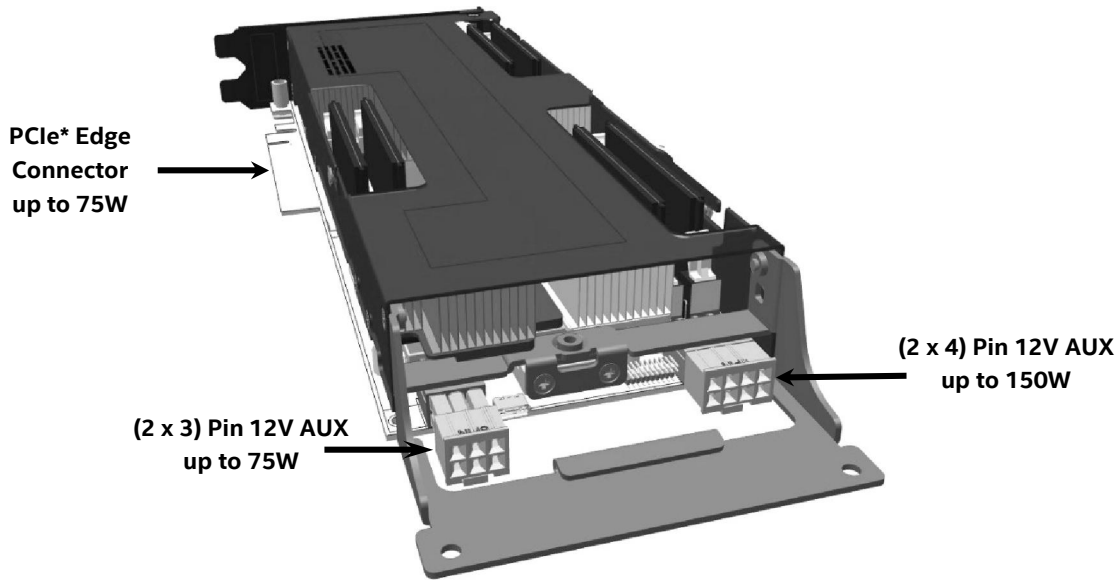

Figure 2. VCA Card Power Connectors

Note: The Intel® Visual Compute Accelerator card does not ship with cables. Contact the system supplier for 12V AUX power cables appropriate for the system to which the card is being installed. See Appendix A for Intel® Server System support.

3.4.1 12V AUX Power Connector Specification and Pinout

- 2 x 3 Pin 12V AUX Power Connector

Vendor – Lotes*

Vendor Part # - APOW0001-P001C01

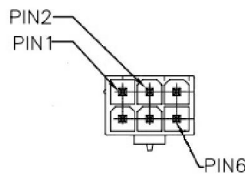

Pin#	Description
1	12V
2	12V
3	12V
4	GND
5	GND
6	GND

- **2 x 4 Pin 12V AUX Power Connector**

Vendor – Lotes

Vendor Part # - APOW0002-P001C01

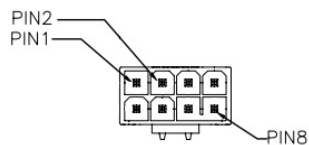

Pin#	Description
1	12V
2	12V
3	12V
4	GND
5	GND
6	GND
7	GND
8	GND

4. Memory

The Intel® Visual Compute Accelerator card includes three processors identified as CPU 1-3. Each of the three processors include two memory channels identified as A and B. Each memory channel supports one SODIMM socket. Each processor can support up to 32GB of memory. The illustration below identifies the SODIMM sockets for each processor.

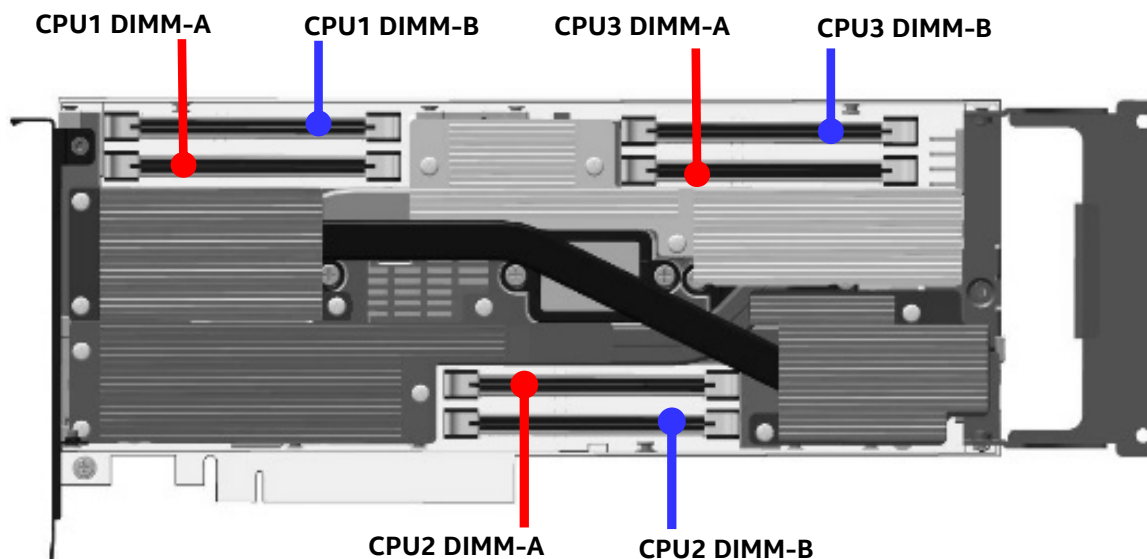

Figure 3. VCA Card DIMM Slots

4.1 Memory Population Rules

Note: Although mixed DIMM configurations may be functional, Intel only supports and performs validation with cards that are configured with identical DIMMs installed across all CPUs

- All DIMMs must be DDR3 DIMMs
- Only Error Correction Code (ECC) enabled DIMMs are supported
- All processors must have at least one DIMM installed
- DIMM slots for each processor must be installed in order beginning with DIMM Slot A
- When only one DIMM is installed for any given processor, it must be populated in the DIMM A slot.

4.2 Supported Memory

The Intel® Visual Compute Accelerator card has support for the following memory type:

Memory Type	Memory Size	Speed	Ranks per DIMM
SODIMM DDR3 x8 ECC	8GB, 16GB	1333, 1600, 1866	SR, DR

4.3 Memory Compatibility List

The following list of memory has been validated for use on the Intel® Visual Compute Accelerator card. This list will be updated as additional DIMMs are tested.

Vendor	8GB	16GB
Micron*	MT18KSF1G72HZ-1G6E2	MT18KSF2G72HZ-1G6A27E
Hynix*	HMT41GA7BFR8A-PB	
Kingston*	KVR16LSE11/8	
Samsung*	M474B1G73BH0- YK0	

5. Operating System Support

Note: All utility software and boot images referenced in this section can be downloaded from the following Intel web site: <http://downloadcenter.intel.com>

The Intel® Visual Compute Accelerator boots the operating system from the host using a technology known as Leverage Boot. A “**vcactl**” utility is used to perform all boot operations. The utility loads the operating system into a RAMDisk which the CPU's boot from.

Users have the option of downloading one of several different boot images available from the Intel web site or creating their own boot image. Refer to the *Intel® Visual Compute Accelerator Product Software Users Guide* for instructions on how to build a boot image.

Alternatively, an option for building a guest OS with pass through graphics is available by using GVT-d virtualization.

For the host operating system, a **virtIO** driver and a utility are required. The driver and utility are currently tested with CentOS* 7.1 (kernel update require).

Disclaimer Note: As these drivers are open source, the option to build them for other Linux based operating systems is available, however Intel cannot provide support for this option without official validation being performed by Intel. Driver validation and performance tuning will be the responsibility of those that choose to build drivers for Linux Operating systems beyond those supported by Intel.

5.1 Supported Host Operating Systems

- CentOS* 7.1 with kernel update

Note: specific kernel updates are documented in the *Intel® Visual Compute Accelerator Product Software Users Guide*.

5.1.1 Reference boot OS on Visual Compute Accelerator

CentOS 7.1 with kernel update

- Persistent Image – Automatically mounts to pre-defined NFS partition on the host. Enables all changes to remain persistent
- Baremetal Image – Full CentOS 7.1 image. By default nothing is persistent.
- w/ Xen Option

5.2 Supported hypervisor

- Xen

5.3 Guest OS

Any OS supported by Intel® Iris Pro Graphics, GVT-d virtualization, and the Intel® Media Server Studio

6. Light Guided Diagnostics

The Intel® Visual Compute Accelerator Board includes several LEDs to indicate the health of the card.

6.1 Power LEDs

Two LEDs located on the back edge of the card, and visible externally from the back of the system, are used to indicate the status of power to the board. One AMBER LED to indicate the status of 3.3V auxiliary power and one GREEN LED to indicate the status of 3.3V main power. Each LED should be illuminated when power is present.

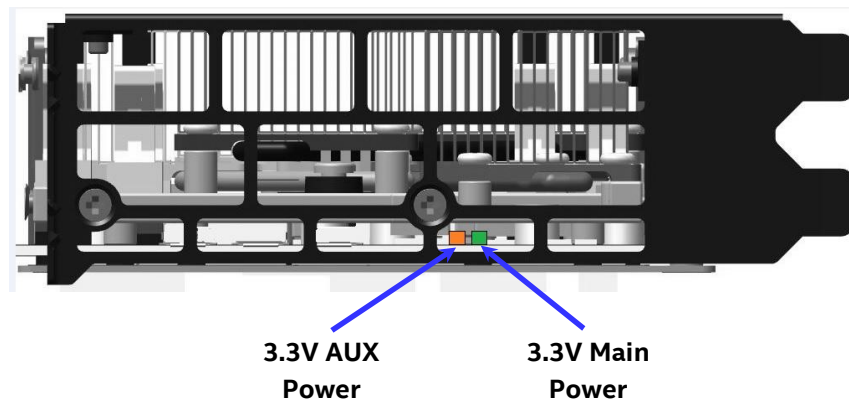

Figure 4. Light Guided Diagnostics - Power State LEDs

6.2 Processor CATERR LEDs

Three LEDs on the back side of the board (viewable when the system is open) are used to indicate when a CATERR for a specific CPU has occurred. When a CATERR on a specific CPU is detected, the given LED will illuminate RED. In a normal state, these LEDs are not illuminated.

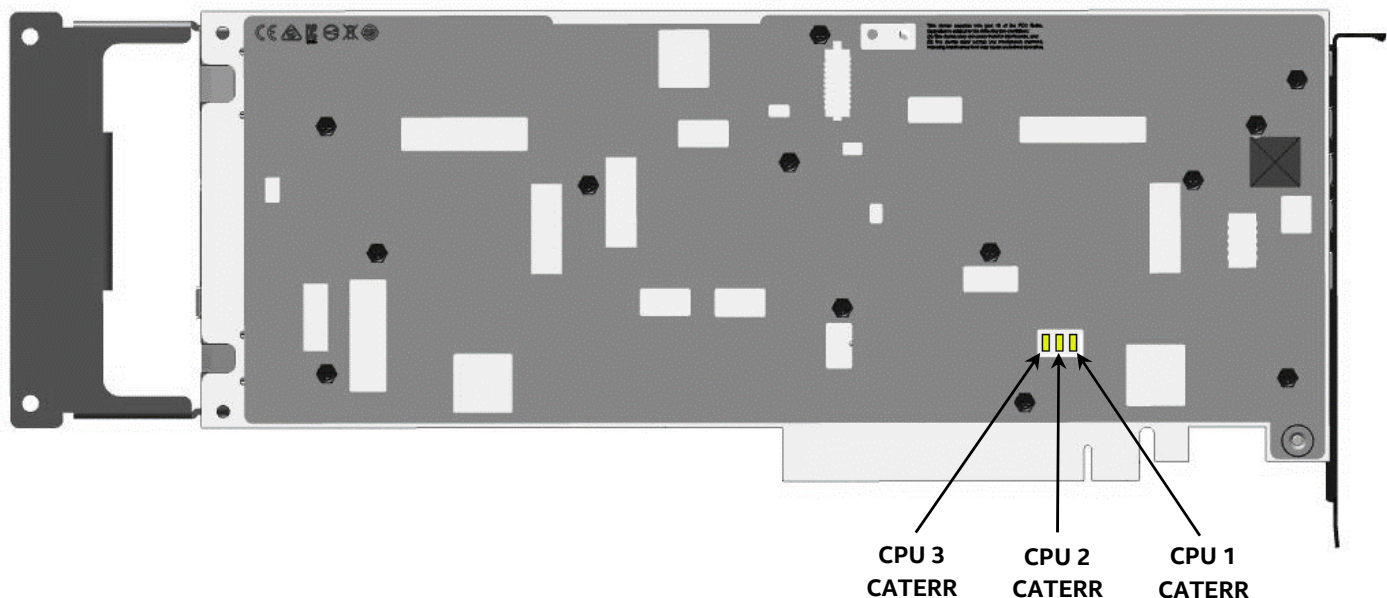

Figure 5. Light Guided Diagnostics - Processor CATERR LEDs

7. BIOS Image Selection Jumpers

The Intel® Visual Compute Accelerator card includes three 16MB SPI Flash devices to store separate BIOS images for each processor. Each flash device will store two BIOS images; a locked factory default image, and a modifiable User Defined image. As shipped from Intel, both BIOS images for each processor will be the factory default.

On the back edge of the VCA card is a set of three jumper blocks. Each jumper block is used to switch the BIOS image for a given processor between the User Defined and the Factory Default. With the jumper in place over the two stake pins (Default), the processor will boot using the User BIOS image. In the rare event the User Image should get corrupted, the jumper can be removed to boot the processor using the Factory Default image.

NOTE: All three jumper blocks should either be installed or removed together. At no time should one jumper setting be different from the other two.

NOTE: The back edge of the VCA card includes several stake pins that are not used and have no functionality. Care should be taken when restoring BIOS Image jumper blocks to their proper stake pin locations. See Figure 6

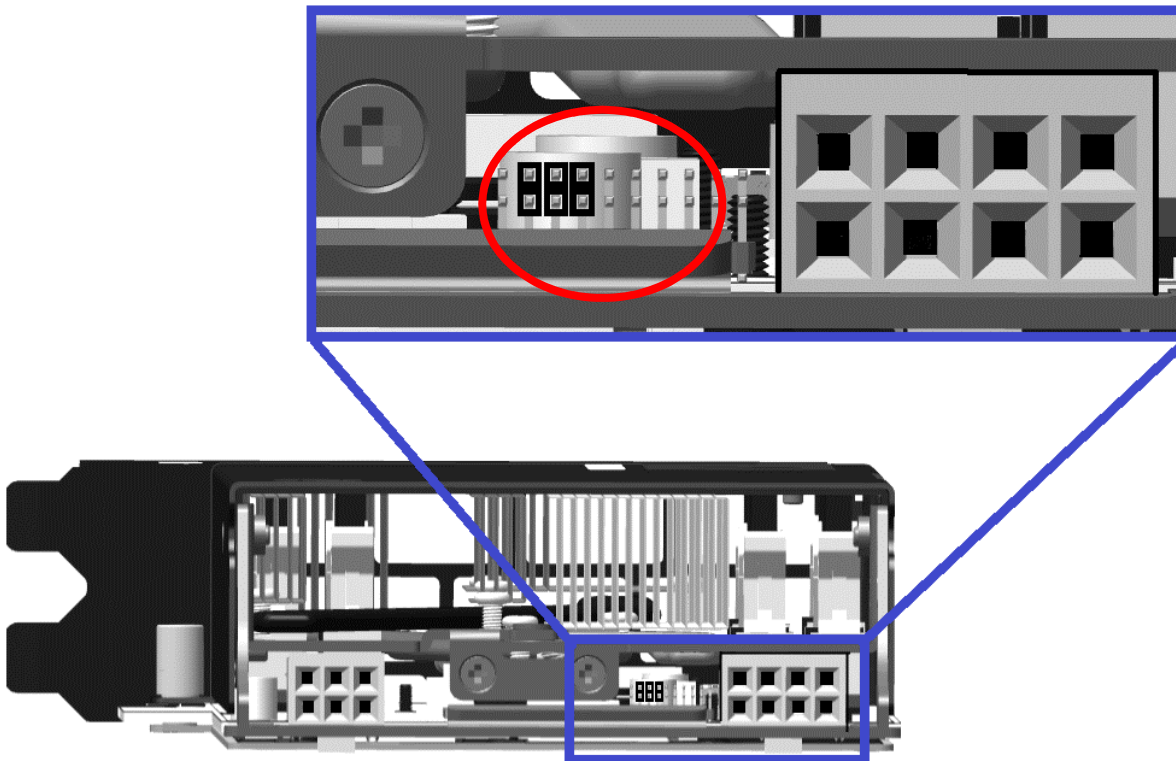

Figure 6. VCA Card BIOS Recovery Jumpers

“OPT_12V_PWR” connectors on the server board. A 12V Aux power cable is routed from the “OPT_12V_PWR” on the server board to a 6 or 8 pin 12V AUX power connector located on the add-in cards.

NOTE: Both the 2-Slot PCIe Riser card and the 12V Auxiliary Power cable are included in Intel Accessory kit A2UL16RISER2

- High power add-in cards with **passive cooling** solutions (no fan on the heat sink) can **only** be supported in systems configured with the high air flow air duct included in Intel Accessory Kit **AWTCOPRODUCT**.

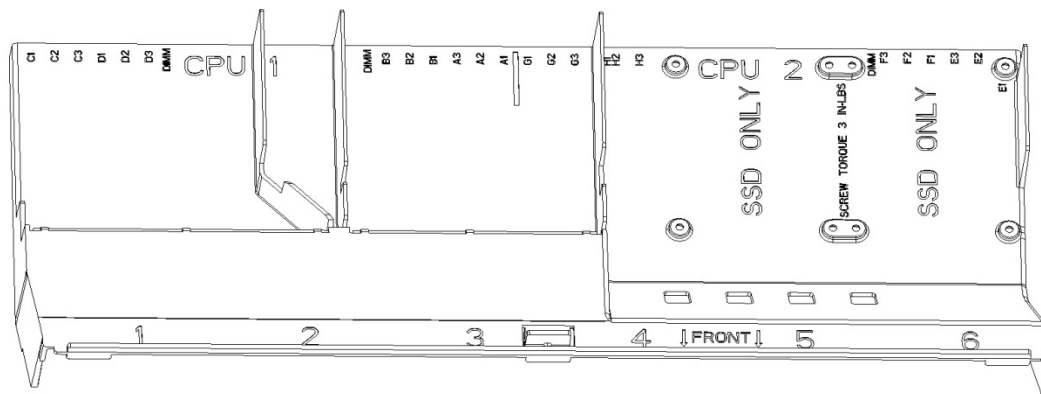

Figure 9. Air Duct included in Intel® Accessory Kit AWTCOPRODUCT

AWTCOPRODUCT Air Duct notes:

The high air flow air duct included in Intel Accessory Kit AWTCOPRODUCT includes two plastic knock-out panels to allow for additional air flow over a specific riser card area. A knock-out panel is only removed when installing a high power add-in card that meets the following criteria:

- Double wide
- Passive Heat Sink Solution (heat sink with no fan attached)

If the add-in card does NOT meet these criteria, the given knock-out panel should **NOT** be removed.

When installing a double wide add-in card with a passive heat sink solution, remove only the plastic knock-out from the side on which the add-in card is installed. Only remove both plastic knock outs when installing two cards that meet the criteria defined above (1 per riser card). Once a knock-out panel is removed, it cannot be re-installed.

- A system configured with the contents of Intel Accessory Kit AWTCOPRODUCT and an Intel® Visual Compute Accelerator card can also support the following additional PCIe* add-in card configurations.
 - PCIe* add-in cards with minimum 100 LFM (0.5 m/s) or 200 LFM (1m/s) air flow requirement can be installed in any available add-in card slot in Riser Card #1, Riser Card #2, and Riser Card #3 (if installed)
 - PCIe* add-in cards with a minimum 300 LFM (1.5 m/s) air flow requirement can be installed in the bottom add-in card slot of Riser Card #1 and Riser Card #2.
 - PCIe* add-in cards with air flow requirement greater than 300 LFM cannot be supported

- Systems configured with an Intel® Visual Compute Accelerator card must have a shipping bracket installed before the system is exposed to any level of shock or vibration or is transported to the end user location. Failure to install the shipping bracket has the potential to cause serious damage to various components within the system. **The shipping bracket is only available as part of the following Intel Accessory Kit: AWT COPRODUCT.**

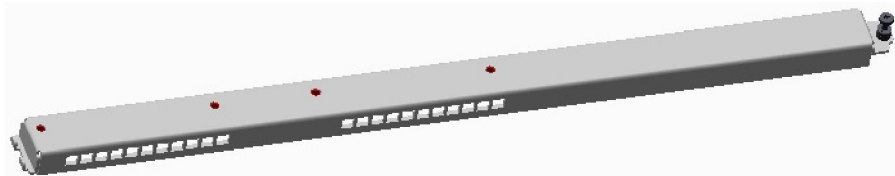

Figure 10. Shipping Bracket

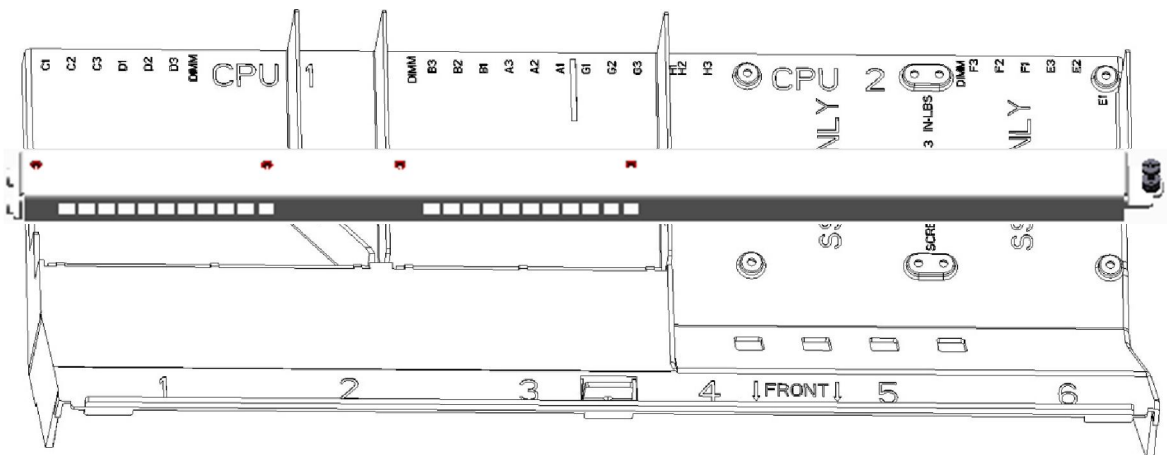

Figure 11. Shipping Bracket Placement

With no shipping bracket installed, the air duct has support for the addition of up to two SSD Storage devices mounted to the air duct via fastener screws. Mounting standard hard disk drives to the air duct is NOT a supported configuration. Mounting hard disk drives to the CPU air duct may cause data loss, performance degradation, and premature drive failures.

High power add-in cards that require up to 300W can be supported. A total system power budget should be calculated to determine if the power draw of the desired system configuration meets the power limits of the installed power supplies. A power budget tool for the specified system can be downloaded from <http://www.intel.com/support>.

The latest posted system software updates must be installed on the system to ensure proper fan speed control is enabled. The latest system update package can be downloaded from the following Intel web site: <http://downloadcenter.intel.com>

Intel® Server System R2000WT family Fan Speed Control

The following IPMI script was developed to provide fan speed control for the Intel® Server System R2000WT product family. The script changes the default Pulse Width Modulation (PWM) offset of the system fans to a value that provides enough airflow to maintain the ambient temperature of the VCA card processors below 96°F. The temperature is retrieved by calling 'vcactl temp' and then as the temperature goes above 95 degrees the fan speed increases. If the temperature drops below 90 degrees the fan speed will decrease. The amount it increases is proportional to how much beyond that threshold the temperature spikes. This offset is beyond the fan speed control already implemented in the BMC so not to impact other components the BMC manages.

```
#!/usr/bin/python

import time

import random

import subprocess

import sys

import re

import math

from subprocess import call

# will hang if program never exits

def runProcess(exe):

    p = subprocess.Popen(exe,stdout=subprocess.PIPE,stderr=subprocess.STDOUT)

    out,err = p.communicate();

    if (p.returncode>0):

        print "Error: Check to ensure vcatl and ipmitool is installed and ipmi service is running"

        exit()

    return out

def getTemperature():

    maxTemp=0

    maxTempNode=""

    output = runProcess("vcactl temp".split())

    it = re.finditer(r"Card\s*\d{1,2}\s*Cpu\s*\d{1,2}",output)

    for match in it:
```

```

it2 = re.search(r"Physical id \d{1,2}:\s*\+\d{1,3}",output[match.start():])
if it2:
    int_list = [int(s) for s in re.findall('\d+',it2.group())]
    if len(int_list)==2 and int_list[1]>maxTemp:
        maxTemp=int_list[1]
        maxTempNode=match.group()
print "Highest temperature is",maxTemp,"on node",maxTempNode
return maxTemp

def setPWMOffset(offset):
    param="ipmitool raw 0x30 0x8C " + hex(math.trunc(offset))
    print "Setting PWM offset to",str(offset)+"%"
    runProcess(param.split())

def getCurrentPWM():
    output = runProcess('ipmitool raw 0x30 0x8D'.split())
    i = int(output,16)
    print "Current PWM offset is",str(i)+"%"
    return i

def changeFan(fan,change):
    lastFan=fan
    fan=fan+change
    # assuming lowest possible base fan is 30 so offset above 70 will never take
    if fan>70.0:
        fan=70.0
    if fan<0.0:
        fan=0.0
    # if nothing changed don't bother running the ipmitool command again
    if lastFan==fan:
        return fan

```

```
setPWMOffset(fan)
```

```
print "Fan is at ",fan
```

```
return fan
```

```
waitTime=10
```

```
proportional=2.5
```

```
fanChange=5
```

```
highTemp=95
```

```
lowTemp=90
```

```
currentTemp=0
```

```
currentFan=getCurrentPWM()
```

```
# main loop
```

```
while True:
```

```
    currentTemp=getTemperature()
```

```
    if currentTemp >= highTemp:
```

```
        currentFan=changeFan(currentFan,(currentTemp-highTemp)*proportional)
```

```
    if currentTemp <= lowTemp:
```

```
        currentFan=changeFan(currentFan,(currentTemp-lowTemp)*proportional)
```

```
    time.sleep(waitTime)
```

